



# EMERGENCY CRANK RADIO/FLASHLIGHT

**Model 98319**

## SET UP AND OPERATING INSTRUCTIONS



Distributed exclusively by Harbor Freight Tools®.

3491 Mission Oaks Blvd., Camarillo, CA 93011

Visit our website at: <http://www.harborfreight.com>



**Read this material before using this product.  
Failure to do so can result in serious injury.  
SAVE THIS MANUAL.**

Copyright© 2008 by Harbor Freight Tools®. All rights reserved. No portion of this manual or any artwork contained herein may be reproduced in any shape or form without the express written consent of Harbor Freight Tools. Diagrams within this manual may not be drawn proportionally. Due to continuing improvements, actual product may differ slightly from the product described herein. Tools required for assembly and service may not be included.

**For technical questions or replacement parts, please call 1-800-444-3353.**

---

## SAVE THIS MANUAL

---

Keep this manual for the safety warnings and precautions, assembly, operating, inspection, maintenance and cleaning procedures. Write the product's serial number in the back of the manual (or month and year of purchase if product has no number). Keep this manual and the receipt in a safe and dry place for future reference.

---

## IMPORTANT SAFETY INFORMATION

---

In this manual, on the labeling, and all other information provided with this product:



This is the safety alert symbol. It is used to alert you to potential personal injury hazards. Obey all safety messages that follow this symbol to avoid possible injury or death.

### **DANGER**

**DANGER** indicates a hazardous situation which, if not avoided, will result in death or serious injury.

### **WARNING**

**WARNING** indicates a hazardous situation which, if not avoided, could result in death or serious injury.

### **CAUTION**

**CAUTION**, used with the safety alert symbol, indicates a hazardous situation which, if not avoided, could result in minor or moderate injury.

### **NOTICE**

**NOTICE** is used to address practices not related to personal injury.

### **CAUTION**

**CAUTION**, without the safety alert symbol, is used to address practices not related to personal injury.

---

## General Product Safety Warnings

---



**WARNING** Read all safety warnings and instructions.

*Failure to follow the warnings and instructions may result in serious injury.*

**Save all warnings and instructions for future reference.**  
*The term "product" in the warnings refers to your battery-operated (cordless) Crank Radio/Flashlight.*

1. **Work area safety**
  - a. **Keep work area clean and well lit.**  
*Cluttered or dark areas invite accidents.*
  - b. **Do not operate this product in explosive atmospheres, such as in the presence of flammable liquids, gases or dust.** *This product can create sparks which may ignite the dust or fumes.*
  - c. **Keep children and bystanders away while operating this product.**  
*Distractions can cause you to lose control.*
2. **Electrical safety**
  - a. **Do not expose this product to rain or wet conditions.** *Water entering this product will increase the risk of product failure and/or electric shock.*

### 3. Personal safety

- a. **Stay alert, watch what you are doing and use common sense when operating this product. Do not use this product while you are tired or under the influence of drugs, alcohol or medication.**

### 4. Product use and care

- a. **Do not force this product. Use the correct product for your application.** *The correct product will do the job better and safer at the rate for which it was designed.*
- b. **Turn the Power Switch (13) to its “OFF” position before making any adjustments, changing accessories, or storing the unit.** *Such preventive safety measures reduce the risk of starting the product accidentally.*
- c. **Store this product out of the reach of children and do not allow persons unfamiliar with the product or these instructions to operate the unit.**
- d. **Maintain this product. Check for misalignment or binding of moving parts, breakage of parts and any other condition that may affect the product’s operation. If damaged, have the product repaired before use.** *Many accidents are caused by poorly maintained products.*
- e. **Use this product in accordance with these instructions, taking into account the working conditions and the work to be performed.** *Use of this product for operations different from those intended could result in a hazardous situation.*

### 5. Battery tool use and care

- a. **Recharge only with the Crank Handle (3).**
- b. **Under abusive conditions, liquid may be ejected from the battery; avoid contact. If contact accidentally occurs, flush with water. If liquid contacts eyes, additionally seek medical help.** *Liquid ejected from the battery may cause irritation or burns.*

### 6. Service

- a. **Have this product serviced by a qualified repair person using only identical replacement parts.** *This will ensure that the safety of the unit is maintained.*

### Additional Precautions

1. Maintain labels and nameplates on the product. These carry important safety information. If unreadable or missing, contact Harbor Freight Tools for a replacement.
2. Avoid unintentional starting. Prepare to begin work before turning on the product.
3. Do not leave the tool unattended when its Power Switch (13) is on. Turn off the unit before leaving.
4. This product is not a toy. Keep it out of reach of children.
5. People with pacemakers should consult their physician(s) before use. Electromagnetic fields in close proximity to heart pacemaker could cause pacemaker interference or pacemaker failure. In addition, people with pacemakers should:

- Avoid operating alone.
- Properly maintain and inspect to avoid electrical shock.

6. The warnings, precautions, and instructions discussed in this instruction manual cannot cover all possible conditions and situations that may occur. It must be understood by the operator that common sense and caution are factors which cannot be built into this product, but must be supplied by the operator.

## SPECIFICATIONS

Product Applications	Designed to provide back-up power for radio, LED lights, alarm, and mobile phone charging functions.
Power Source	Dynamo Charger 3.6VDC 120mAh Lithium Battery
Light Source	3 Light Emitting Diodes (LED'S)
Radio Run Time	1 Minute Crank Time = 5-10 Minutes Radio Run Time
Light On Duration	1 Minute Crank Time = 3 LED's for More Than 30 Minutes. 1 Minute Crank Time = 1 LED for More Than 1-1/2 Hours.
Mobile Phone Power Duration	1 Minute Crank Time = 2-8 Minutes Talk Time / 40-50 Minutes Standby.
Alarm Loudness	97 dB @ 12 Inches
Accessories	Mobile Phone Charger Cord and Adapter (3.5mm O.D. / 1.1mm I.D.)

## UNPACKING

When unpacking, check to make sure that the item is intact and undamaged. If any parts are missing or broken, please call Harbor Freight Tools at the number shown on the cover of this manual as soon as possible.

## OPERATING INSTRUCTIONS



Read the **ENTIRE IMPORTANT SAFETY INFORMATION** section at the beginning of this manual including all text under subheadings therein before set up or use of this product.

**Note:** For additional information regarding the parts listed in the following pages, refer to the Assembly Diagram near the end of this manual.

## Product Features

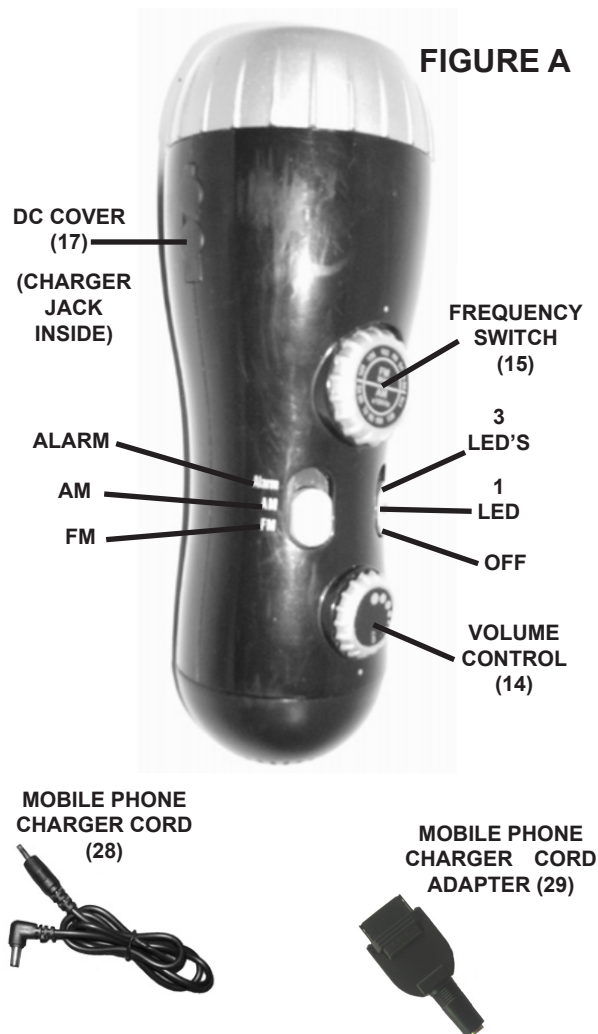

1. Check to make sure the Switch Button (13) is in its **“OFF”** position. **(See Figure A.)**
2. To charge the internal Battery (27), pull out the Crank Handle (3) and rotate the Handle clockwise at a steady rate for approximately one minute. Then place the Crank Handle back in its original position. **(See Figure B.)**

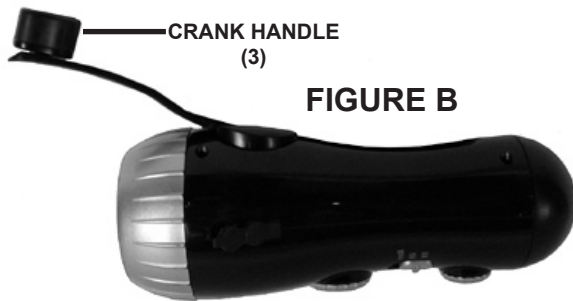

**FIGURE B**

3. The Emergency Crank Radio/Flashlight features **AM** and **FM** frequencies.
  - Charge the internal Battery (27) for one minute by rotating the Crank Handle (3). Then turn the Switch Button (13) to either its **“AM”** or **“FM”** function. **(See Figure A.)**
  - Turn the Frequency Switch (15) to the correct **“AM”** or **“FM”** frequency to select the desired radio station. **(See Figure A.)**
4. The Emergency Crank Radio/Flashlight features *two* LED Light functions:
  - Charge the internal Battery (27) for one minute by rotating the Crank Handle (3). Then turn the Switch Button (13) to its **“1 LED”** position. One LED Light on the unit will illuminate for approximately 1-1/2 hours before recharging is necessary. **(See Figure A.)**
  - Charge the internal Battery (27) for one minute by rotating the Crank Handle (3). Then turn the Switch Button (13) to its **“3 LED”** position. All three LED Lights on the unit will illuminate for approximately 30 minutes before recharging is necessary. **(See Figure A.)**
5. To operate the Alarm on the unit, simply turn the Switch Button (13) to its **“ALARM”** function. **(See Figure A.)**
6. To charge a mobile phone, using the Emergency Crank Radio/Flashlight:
  - Charge the internal Battery (27) for one minute by rotating the Crank Handle (3). Then open the DC Cover (17). **(See Figure A.)**
  - Plug one end of the Mobile Phone Charger Cord (28) into the Charging Jack on the unit. Plug the other end of the Charger Cord into the mobile phone you wish to charge. **(See Figure A.)**
  - NOTE: One minute of crank time on the Crank Handle (3) will allow for 2 to 8 minutes mobile phone talk time or 40-50 minutes standby.
7. When finished using the Emergency Crank Radio/Flashlight, make sure to turn the Switch Button (13) to its **“OFF”** position. Then store the unit in a clean, dry, safe location out of reach of children and other unauthorized persons.

---

## MAINTENANCE AND SERVICING

---



Procedures not specifically explained in this manual must be performed only by a qualified technician.

### **⚠️ WARNING**

#### **TO PREVENT POSSIBLE INJURY**

##### **FROM ACCIDENTAL OPERATION:**

**Turn the Switch Button (13) of the Emergency Crank Radio/ Flashlight to its “OFF” position before performing any inspection, maintenance, or cleaning procedures.**

##### **TO PREVENT POSSIBLE INJURY FROM PRODUCT FAILURE:**

**Do not use a damaged product. If abnormal noise or vibration, or Battery leakage occurs, have the problem corrected before further use.**

---

### **Inspection, Maintenance, and Cleaning**

1. BEFORE EACH USE, inspect the general condition of the Emergency Crank Radio/Flashlight. Check for loose screws, cracked or broken parts, damaged electrical wiring, battery leakage, and any other condition that may affect its safe operation.
2. NOTE: Only a qualified service technician should attempt to replace the Rechargeable Battery (27) in this unit.
3. AFTER USE, clean external surfaces of the tool with clean cloth and mild

detergent. Do not use solvents. Do not immerse the unit in liquid.

---

### **PLEASE READ THE FOLLOWING CAREFULLY**

---

THE MANUFACTURER AND/OR DISTRIBUTOR HAS PROVIDED THE PARTS LIST AND ASSEMBLY DIAGRAM IN THIS MANUAL AS A REFERENCE TOOL ONLY. NEITHER THE MANUFACTURER OR DISTRIBUTOR MAKES ANY REPRESENTATION OR WARRANTY OF ANY KIND TO THE BUYER THAT HE OR SHE IS QUALIFIED TO MAKE ANY REPAIRS TO THE PRODUCT, OR THAT HE OR SHE IS QUALIFIED TO REPLACE ANY PARTS OF THE PRODUCT. IN FACT, THE MANUFACTURER AND/OR DISTRIBUTOR EXPRESSLY STATES THAT ALL REPAIRS AND PARTS REPLACEMENTS SHOULD BE UNDERTAKEN BY CERTIFIED AND LICENSED TECHNICIANS, AND NOT BY THE BUYER. THE BUYER ASSUMES ALL RISK AND LIABILITY ARISING OUT OF HIS OR HER REPAIRS TO THE ORIGINAL PRODUCT OR REPLACEMENT PARTS THERETO, OR ARISING OUT OF HIS OR HER INSTALLATION OF REPLACEMENT PARTS THERETO.



## PARTS LIST & ASSEMBLY DIAGRAM

Part #	Description	Qty.	Part #	Description	Qty.
1	Lower Housing	1	15	Frequency Switch	1
2	Upper Housing	1	16	Motor Assembly	1
3	Crank Handle	1	17	DC Cover	1
4	Handle Sleeve	1	18	Radio Board	1
5	Handle	1	19	Speaker Cover	1
6	Pin	1	20	Speaker	1
7	Rotary Wheel	1	21	Tap Screw (ST2x10)	4
8	Lens	1	22	Tap Screw (PW-ST2x8)	1
9	Reflector	1	23	Tap Screw (ST2x5)	3
10	Head Cover	1	24	Tap Screw (ST2 x8)	4
11	LED Board	1	25	Tap Screw (ST3x8)	1
12	Charging Socket Board	1	26	Tap Screw (ST1.6x4)	2
13	Switch Button	2	27	Rechargeable Battery	1
14	Volume Switch	1	28	Mobile Phone Charger Cord	1
			29	Mobile Phone Charger Adapter	1

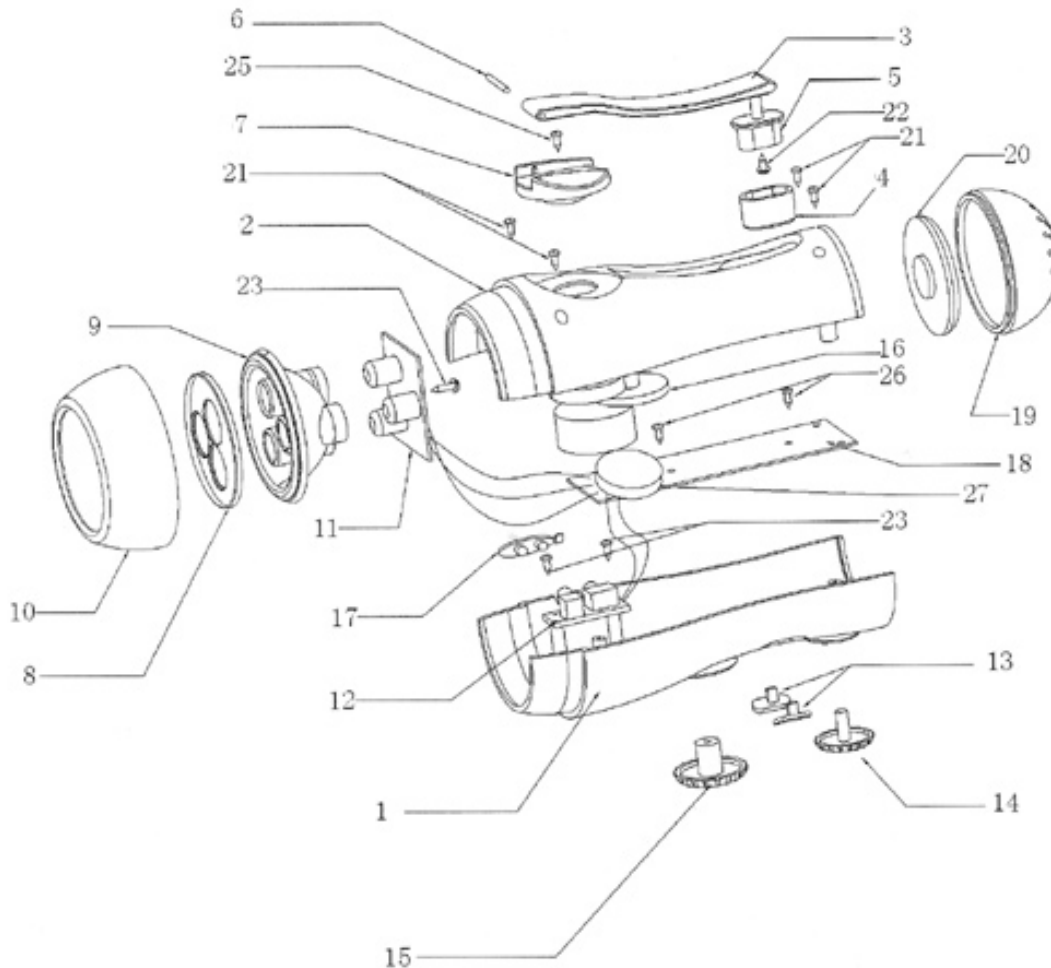

---

## LIMITED 90 DAY WARRANTY

---

Harbor Freight Tools Co. makes every effort to assure that its products meet high quality and durability standards, and warrants to the original purchaser that this product is free from defects in materials and workmanship for the period of 90 days from the date of purchase. This warranty does not apply to damage due directly or indirectly, to misuse, abuse, negligence or accidents, repairs or alterations outside our facilities, criminal activity, improper installation, normal wear and tear, or to lack of maintenance. We shall in no event be liable for death, injuries to persons or property, or for incidental, contingent, special or consequential damages arising from the use of our product. Some states do not allow the exclusion or limitation of incidental or consequential damages, so the above limitation of exclusion may not apply to you. THIS WARRANTY IS EXPRESSLY IN LIEU OF ALL OTHER WARRANTIES, EXPRESS OR IMPLIED, INCLUDING THE WARRANTIES OF MERCHANTABILITY AND FITNESS.

To take advantage of this warranty, the product or part must be returned to us with transportation charges prepaid. Proof of purchase date and an explanation of the complaint must accompany the merchandise. If our inspection verifies the defect, we will either repair or replace the product at our election or we may elect to refund the purchase price if we cannot readily and quickly provide you with a replacement. We will return repaired products at our expense, but if we determine there is no defect, or that the defect resulted from causes not within the scope of our warranty, then you must bear the cost of returning the product.

This warranty gives you specific legal rights and you may also have other rights which vary from state to state.

**3491 Mission Oaks Blvd. • PO Box 6009 • Camarillo, CA 93011 • (800) 444-3353**

**Record Product's Serial Number Here:** \_\_\_\_\_

**Note:** If product has no serial number, record month and year of purchase instead.

**Note:** Some parts are listed and shown for illustration purposes only, and are not available individually as replacement parts.